

The HORI 550v uses technology similar to a piston compressor but is absolutely oil free. It has been designed specifically for the European markets as a superb advance over other compressors. This next generation product incorporates the original Japanese technology with advanced features allowing it to operate up to 3,0 bar pressure in a compact new design. It can be driven in any direction which takes away the risk of any wrong rotation.

Suitable for:- **Powders: Cement, Flour, Calcium Carbonate, Fly Ash, Hydrated Lime etc.**

Liquids: liquid foodstuff, solvents, acids, alkalis, hot bitumen resins and other chemicals

- ★ **Dry Bulk & Liquids**
- ★ 2,5 bar continuous
- ★ 2,8 bar Relief Valve
- ★ 75 m³/h to 700m³/h
- ★ Oil free
- ★ Low Noise
- ★ Low Power
- ★ Maintenance almost zero
- ★ **Bi- Rotational**
- ★ **Direct PTO Drive**
- ★ **Low input speed**
- ★ 500 rpm to 1500 rpm
- ★ **Standard 3 year Warranty**
- ★ **150 kg inc. Accessories**
- ★ **Low Cost**
- ★ **Bearing Life 20 years +**

HORI 550v

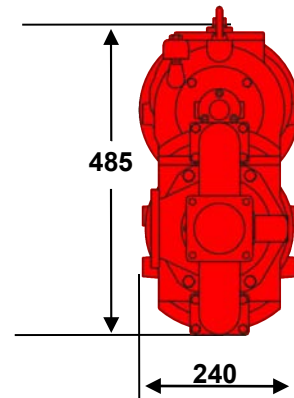
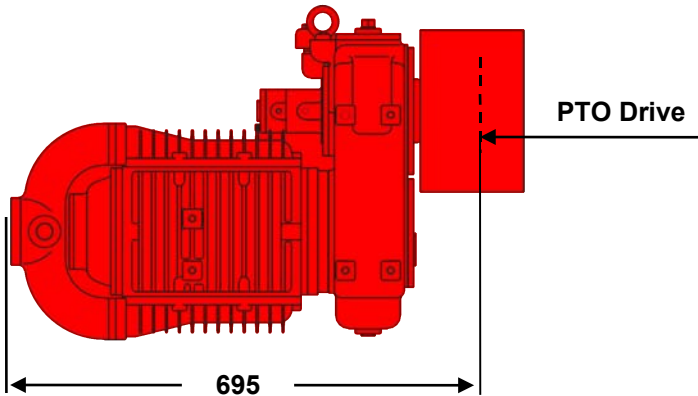

Description	Unit	Details
Flow at inlet (2,0 bar)	m ³ /h	min. 75 max. 550
Input speed	rpm	min. 500 max. 1500
Working Pressure	bar (g)	max. 2,5 bar continuous
Power consumption (2,0 bar)	kW	21 max.
Power consumption (2,5 bar)	kW	25 max.
Dimensions	mm	240 x 485 x 779
Weight inc. accessories	kg	150

Benefits

- ✦ Oil free
- ✦ 2,5 bar continuous
- ✦ 2,8 bar relief valve
- ✦ Oil change 1 time per year (common motor oil)
- ✦ No other maintenance
- ✦ Standard 3 year guarantee
- ✦ In chassis installation
- ✦ Bi – rotation input drive
- ✦ Long bearing life (20 years +)

Advantages

- ✦ Low noise
- ✦ Low power
- ✦ Low weight
- ✦ Low maintenance
- ✦ Low bearing rpm
- ✦ Low rotor rpm
- ✦ Low input rpm
- ✦ Low fuel consumption
- ✦ Low cost